

TMPM4G9F15FG Evaluation Board Schematics

01. THIS SHEET
02. MCU TMPM4G9F15FG (Cortex-M4)
03. PIN HEADER / Arduino CN
04. DAP TMPM366FDXBG
05. USER IO

TMPM4G9F15FG Port Assign

PA0-4...SPI to Arduino
 PA5 ...PWM to Arduino10
 PA6-7... GPIO

PB0-1... GPIO
 PB2 ...PWM to Arduino03
 PB3 ... GPIO
 PB4 ...PWM to Arduino05
 PB5-7... GPIO

PC0-1... GPIO
 PC2 ...PWM to Arduino06
 PC3 ... GPIO
 PC4 ...PWM to Arduino05
 PC5-7... GPIO

PD0-1...GPIO to M366
 PD2-7... GPIO

PE0-1... GPIO
 PE2-3...UART to USB
 PE4-7...GPIO for LED

PF0 ... GPIO
 PF1 ...nRESET
 PF2-3... GPIO
 PF4-6...GPIO to Arduino (02,04,07)
 PF7 ... GPIO

PG0-1... GPIO
 PG2-3...I2C to Arduino
 PG4-5... GPIO
 PG6-7...TRACE

PH0-2...TRACE
 PH3-7...JTAG/SWD

PJ0-1...UART to Arduino
 PJ2-5... GPIO
 PJ6-7...I2C to EEPROM

PK0-1... GPIO
 PK2-7...SMI to SPI-Flash

PL0 ...INT from STOP-SW
 PL1-3... GPIO
 PL4-5...INT from SW1+2
 PL6 ...PWM for 1kHz
 PL7 ... GPIO

PM0-1...GPIO from DIP-SW
 PM2-7... GPIO

PN0-5...AnalogIN from Arduino
 PN6-7... GPIO

PP0-1...AnalogIN from VR
 PP2-7... GPIO

PR0 ...AnalogIN from NTC
 PR1-2... GPIO
 PR3 ...1kHzPWM return
 PR4-7... GPIO

PT0-1...DAC output
 PT2 ...CEC of HDMI
 PT3 ...RemoCon in
 PT4 ... GPIO
 PT5 ...INT from Tri-AXIS

PU0-1...UART to M366
 PU2-5... GPIO
 PU6 ...PWM to Arduino11
 PU7 ... GPIO

PV0-1...ISD from SW3+4
 PV2-3... GPIO
 PV4-7...SPI to SPI-Flash

PW0-3...SPI to Tri-AXIS
 PW4-7... GPIO

PY0-3...X'tal
 PY4 ...BOOT

PE1	2	PE0
PD7	4	PD4
PD5	6	PD1
PD3	8	PD0
M366-IO1	10	PU5
M366-IO0	11	PU6
PU7	12	PU4
Ar11_PWM	13	PU2
PU3	14	PU1
PY4	15	PU0
M366-UT_RX	16	PT3
M366-UT_TX	17	PT2
PMC	18	PT1
Ar10_SPI_CS0	19	PA1
Ar13_SPI_SCK	20	PA2
Ar12_SPI_RX	21	PA3
Ar11_SPI_TX	22	PA4
Ar08_SPI_CS1	23	PA5
Ar10_PWM	24	PA7
PA6	25	PB1
PB0	26	PB2
Ar03_PWM	27	PB3
PB3	28	PB4
Ar05_PWM	29	PB5
PB6	30	PC1
PC0	31	PC2
Ar06_PWM	32	PC5
PB6	33	PC4
Ar09_PWM	34	PC7
PC6	35	PC5
Ar07_IO	36	PC6
Ar04_IO	37	PC7
Ar04_IO	38	PF5
Ar04_IO	39	PF5
Ar04_IO	40	PF5
Ar04_IO	41	PF5
Ar04_IO	42	PF5
Ar04_IO	43	PF5
Ar04_IO	44	PF5
Ar04_IO	45	PF5
Ar04_IO	46	PF5
Ar04_IO	47	PF5
Ar04_IO	48	PF5
Ar04_IO	49	PF5
Ar04_IO	50	PF5
Ar04_IO	51	PF5
Ar04_IO	52	PF5
Ar04_IO	53	PF5
Ar04_IO	54	PF5
Ar04_IO	55	PF5
Ar04_IO	56	PF5
Ar04_IO	57	PF5
Ar04_IO	58	PF5
Ar04_IO	59	PF5
Ar04_IO	60	PF5
Ar04_IO	61	PF5
Ar04_IO	62	PF5
Ar04_IO	63	PF5
Ar04_IO	64	PF5

LED0	1	2	PE4
LED1	3	4	PE5
LED2	5	6	PE6
LED3	7	8	PE7
TRI_INT0	9	10	PT5
TRI_SPI_TX	11	12	PW3
TRI_SPI_RX	13	14	PW2
TRI_SPI_SCK	15	16	PW1
TRI_SPI_CS	17	18	PW0
GND	19	20	PM4
PH5	21	22	PM5
GND	23	24	PH4

USB_UT_RX	1	2	PE2
USB_UT_TX	3	4	PE3
EEPROM_I2C_SCL	5	6	PJ7
EEPROM_I2C_SDA	7	8	PJ6
PJ5	9	10	PJ4
SPI_FLASH_CS	11	12	PV7
SPI_FLASH_SCK	13	14	PV6
SPI_FLASH_TX	15	16	PV5
SPI_FLASH_RX	17	18	PV4
PM7	19	20	PM6
PH7	21	22	PH6
PH3	23	24	PH2

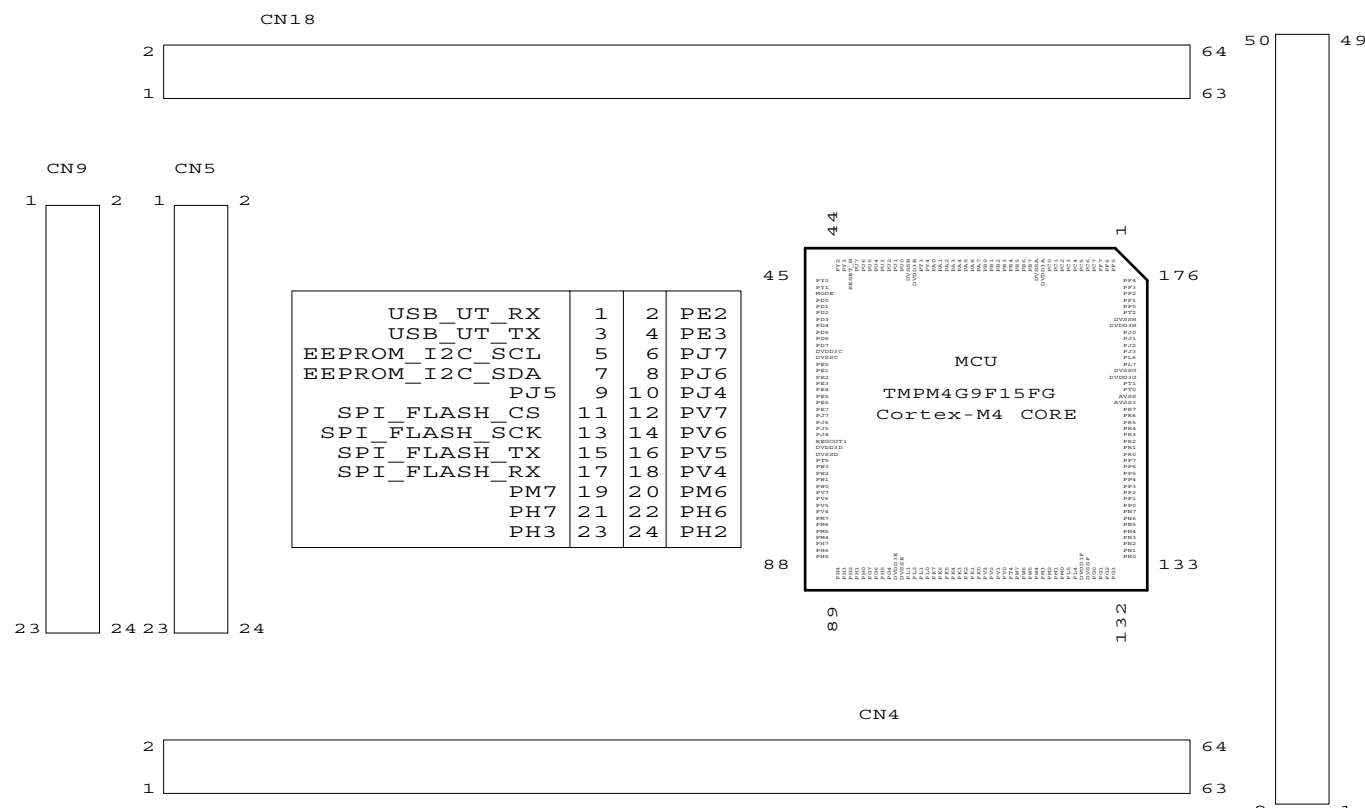

VCC5.0	50	49	GND
DVCC	48	47	GND
PF0	46	45	GND
PF4	44	43	Ar02_IO
PF3	42	41	GND
PF2	40	39	GND
PF1	38	37	nRESET
PT2	36	35	HDMI_CEC
PJ0	34	33	Ar_UT_RX
PJ1	32	31	Ar_UT_TX
PF7	30	29	PJ2
PL6	28	27	PR3
PL7	26	25	PJ3
PT1	24	23	DAC1
PT0	22	21	DAC0
PR6	20	19	PR7
PR4	18	17	PR5
PR2	16	15	PR1
PR0	14	13	AIN_NTC
PP7	12	11	PP6
PP5	10	9	PP4
PP3	8	7	PP2
PP1	6	5	AIN_VR1
PP0	4	3	AIN_VR0
PN7	2	1	PN6

PH0	2	PH1
PG6	4	PG7
PG4	6	PG5
PL2	8	PL3
PL0	10	StopSW_INT
PK1	11	SMI_CS0
PK7	13	SMI_CLK
PK6	14	SMI_D3
PK5	15	SMI_D2
PK4	16	SMI_D1
PK3	17	SMI_D0
PK2	18	SMI_D0
PV3	19	PV2
PT4	20	ISD_SW1
PV1	21	ISD_SW0
PV0	22	PW7
PW6	23	PW5
PW4	24	PW3
PM2	25	PM1
PM1	26	DIPSW1
PM0	27	DIPSW0
PL5	28	SW_INT1
PL4	29	SW_INT0
PG1	30	PG0
PG2	31	Ar_I2C_SDA
PG3	32	Ar_I2C_SCL
PNO	33	Ar_AIN0
PN1	34	Ar_AIN1
PN2	35	Ar_AIN2
PN3	36	Ar_AIN3
PN4	37	Ar_AIN4
PN5	38	Ar_AIN5
PN5	39	Ar_AIN5
PN5	40	Ar_AIN5
PN5	41	Ar_AIN5
PN5	42	Ar_AIN5
PN5	43	Ar_AIN5
PN5	44	Ar_AIN5
PN5	45	Ar_AIN5
PN5	46	Ar_AIN5
PN5	47	Ar_AIN5
PN5	48	Ar_AIN5
PN5	49	Ar_AIN5
PN5	50	Ar_AIN5
PN5	51	Ar_AIN5
PN5	52	Ar_AIN5
PN5	53	Ar_AIN5
PN5	54	Ar_AIN5
PN5	55	Ar_AIN5
PN5	56	Ar_AIN5
PN5	57	Ar_AIN5
PN5	58	Ar_AIN5
PN5	59	Ar_AIN5
PN5	60	Ar_AIN5
PN5	61	Ar_AIN5
PN5	62	Ar_AIN5
PN5	63	Ar_AIN5
PN5	64	Ar_AIN5

[HISTORY]

2017/8/31 Rev.02 Release

					Project
					Board Name
					TMPM4G9_rev05.cir/00
Rev	Date	作成	確認	承認	変更内容
	18/08/22 15:07:21 yamada				
					Page
					Page 1 of 5

02. MCU TPM4G9F15FG (Cortex-M4) / JTAG / POWER

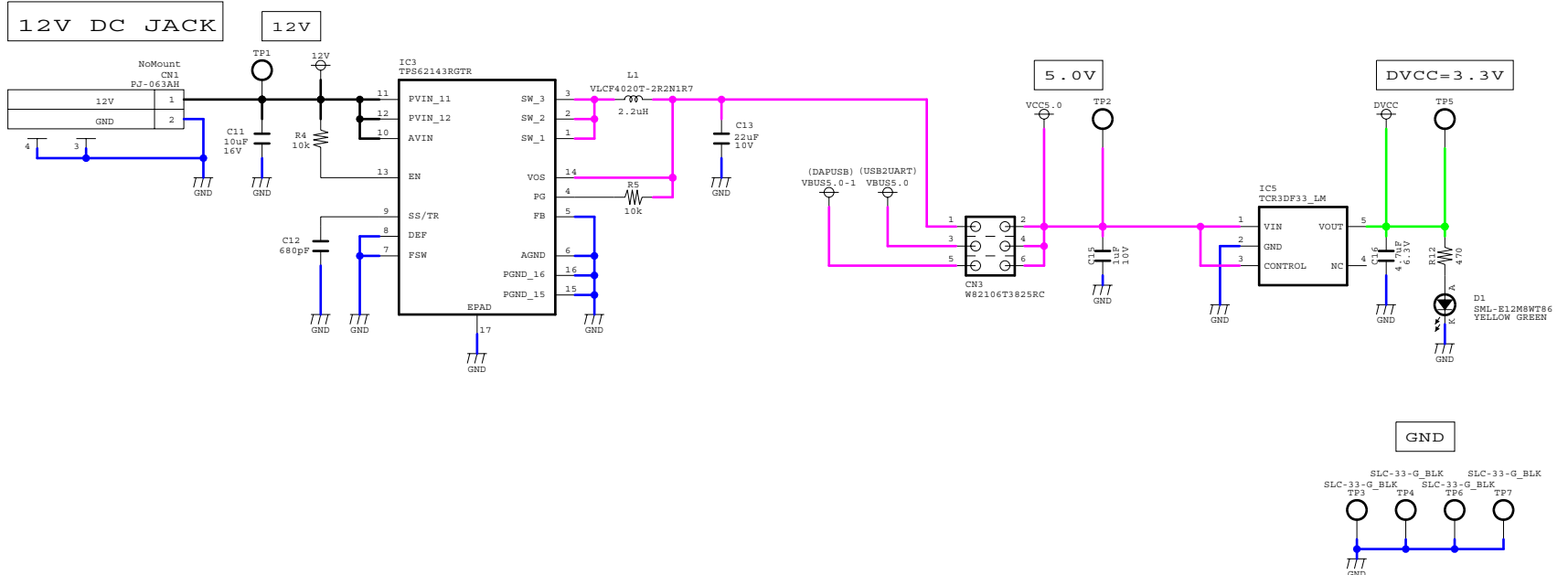
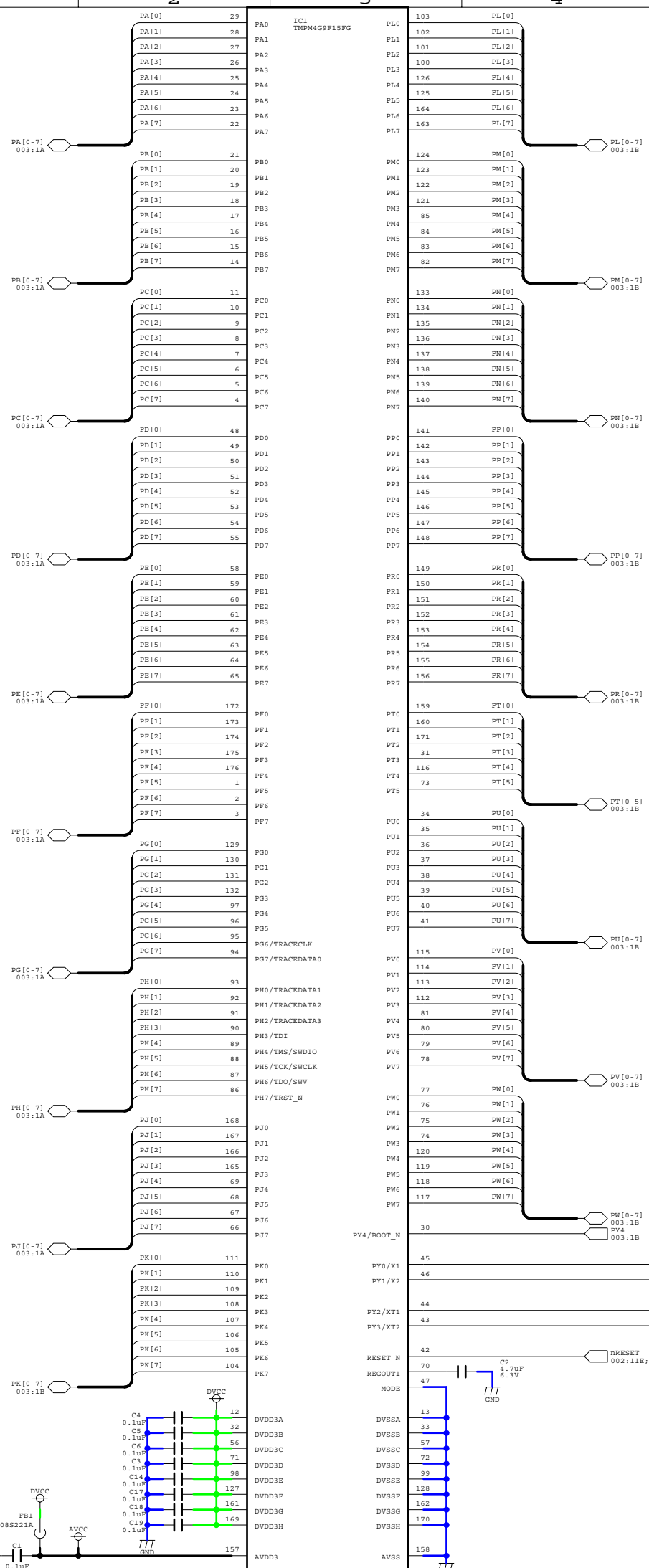

ARM-20

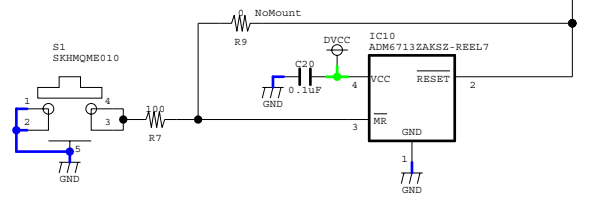
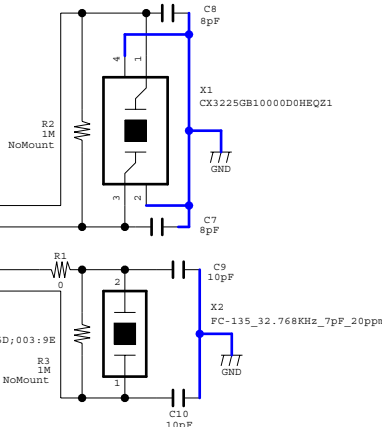
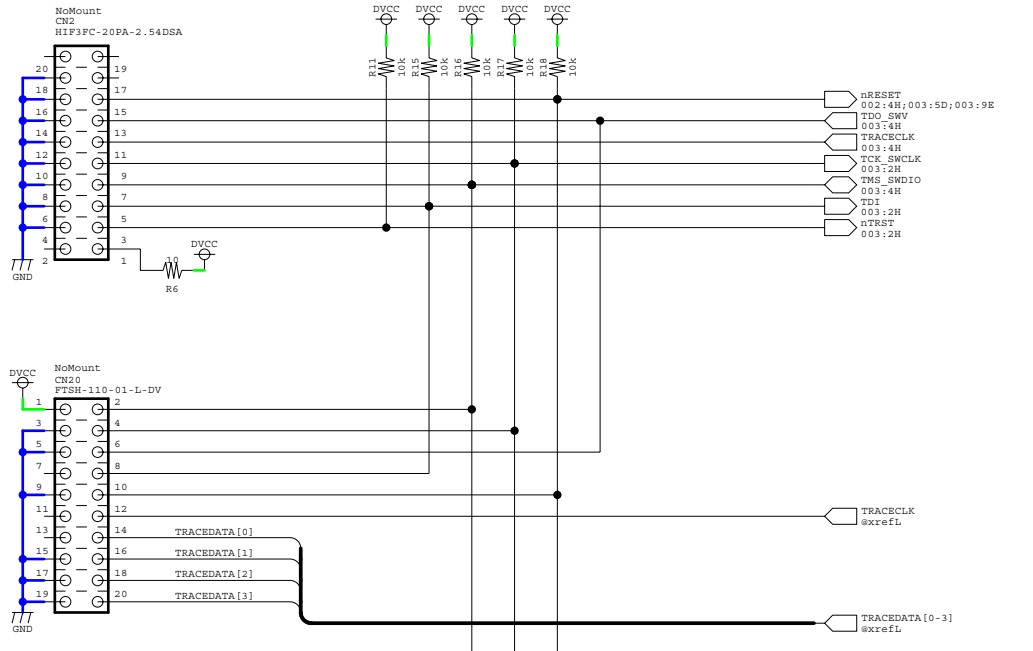
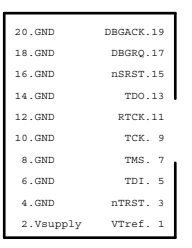

Project				
Board Name				
TMPM4G9_rev05.cir/00				
Rev	Date	作成	確認	承認
	18/08/22	yamada		
変更内容				
Page				
Page 2 of 5				

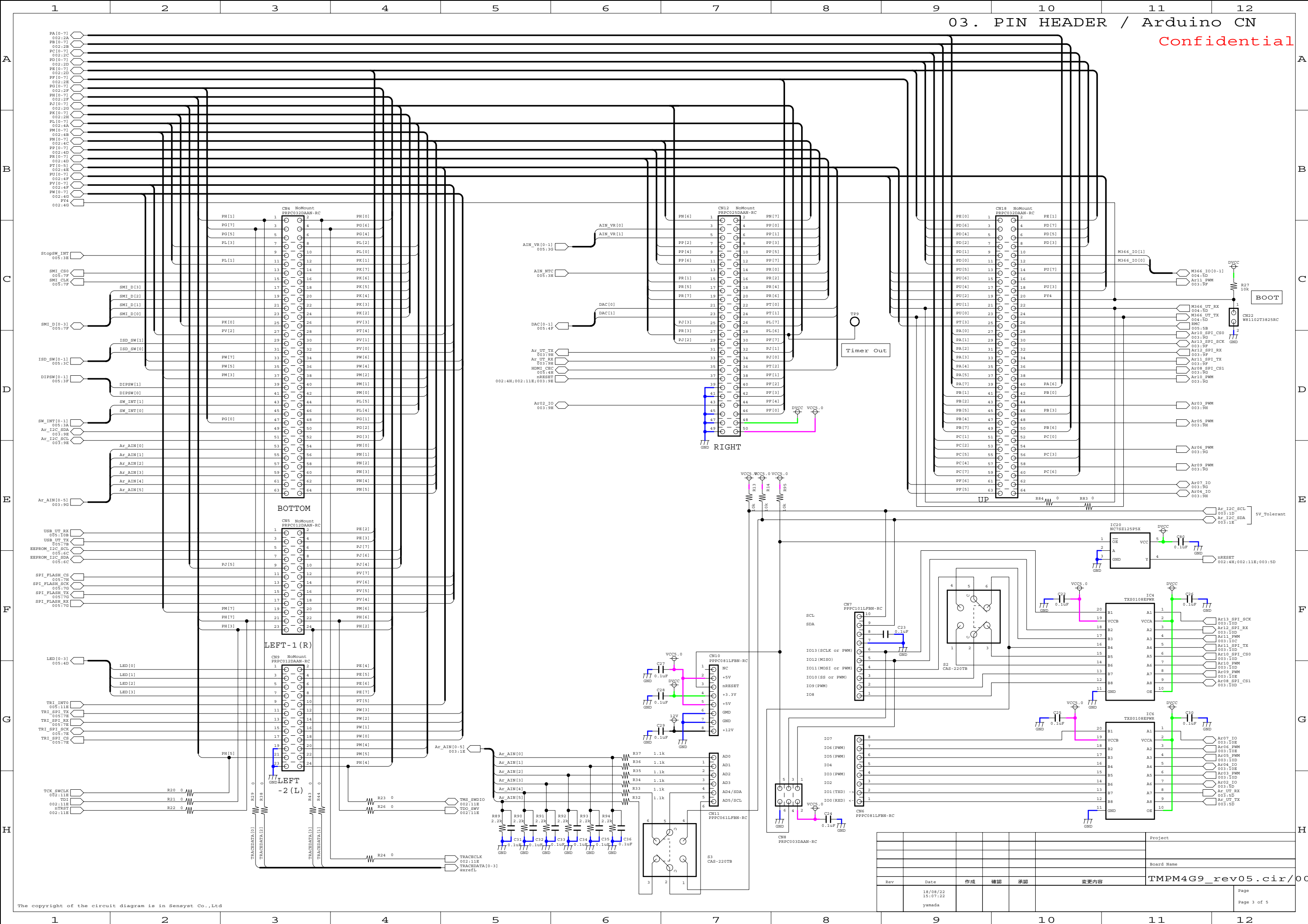

					Project
					Board Name
Rev	Date	作成	確認	承認	変更内容
	18/08/22 15:07:22	yamada			TMPM4G9_rev05.cir/00
					Page
					Page 3 of 5

04. DAP TPM366FDXBG / SLC NAND

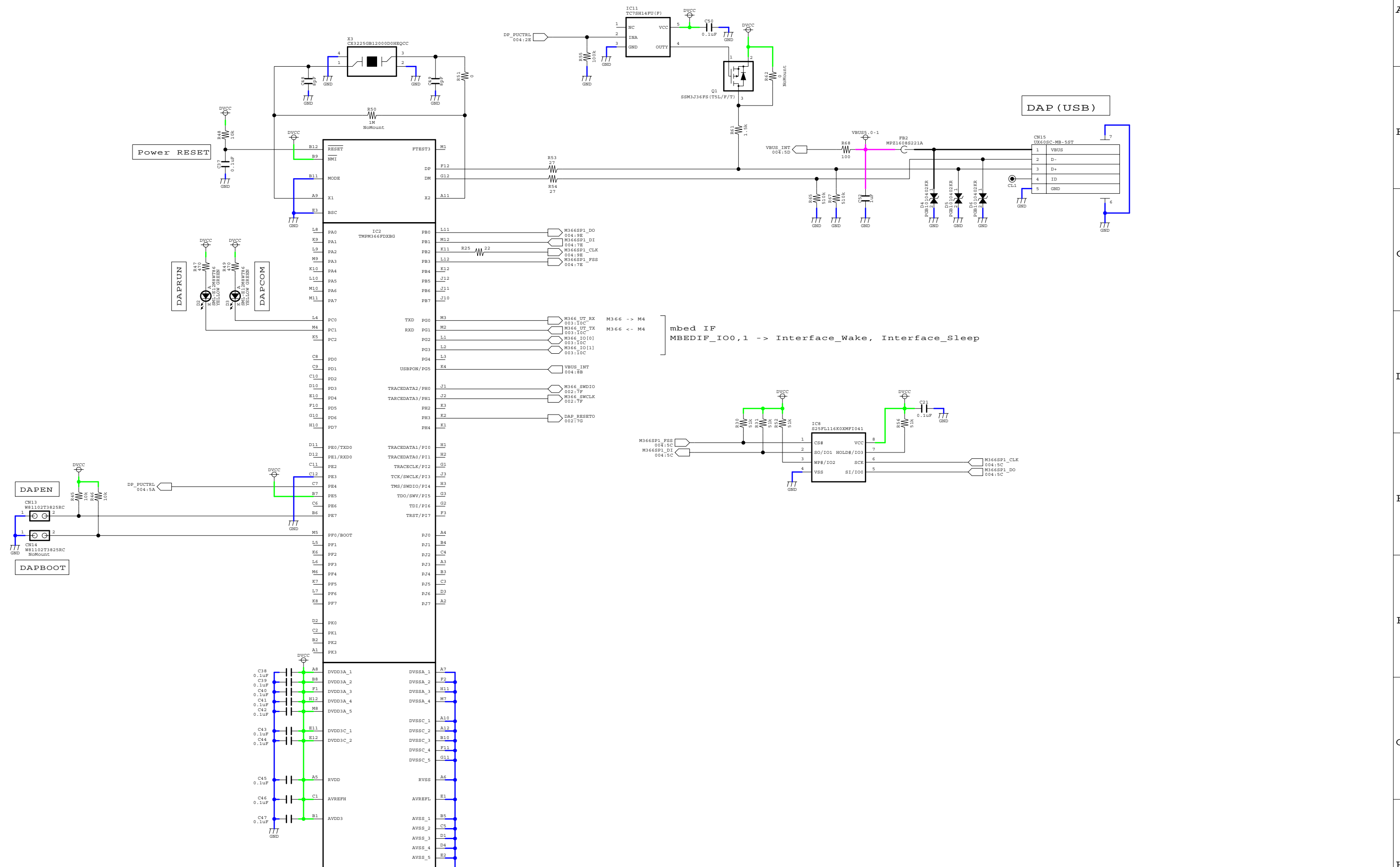

mbed IF
 MBEDIF_IO0,1 -> Interface_Wake, Interface_Sleep

					Project
					Board Name
					TMPM4G9_rev05.cir/00
Rev	Date	作成	確認	承認	変更内容
	18/08/22 15:07:22 yamada				
					Page Page 4 of 5

05. USER IO

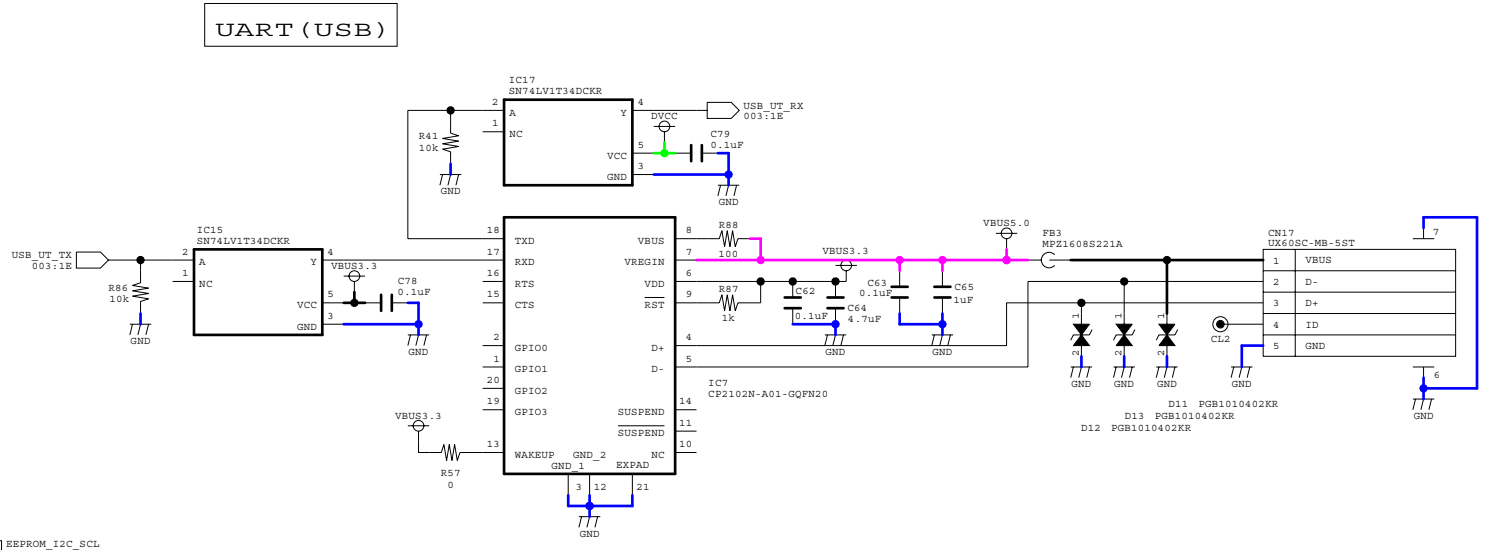
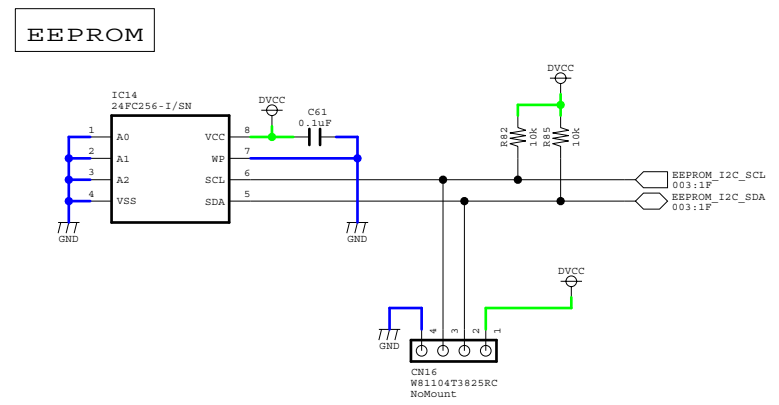
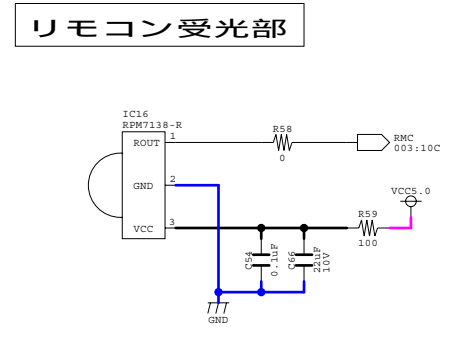
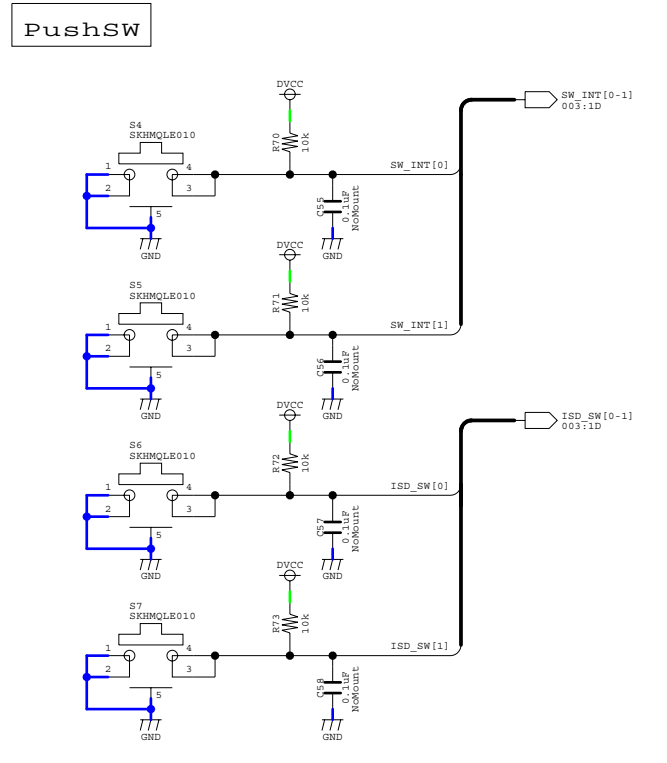

Tri-AXIS Gyroscope Tri-AXIS Accelometer

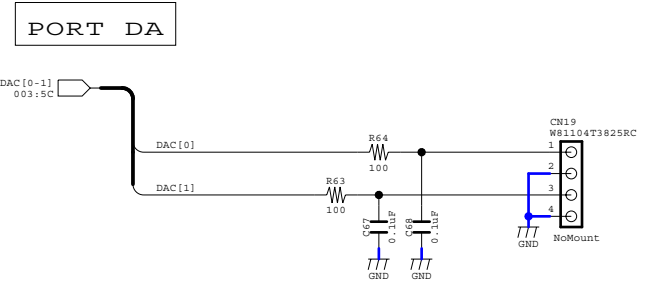
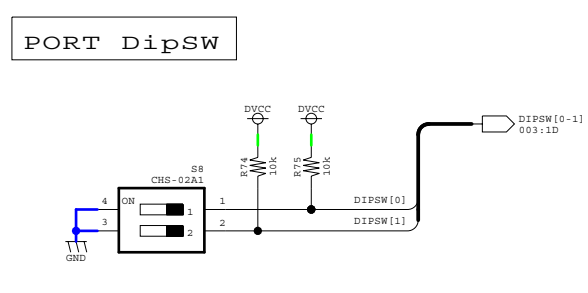
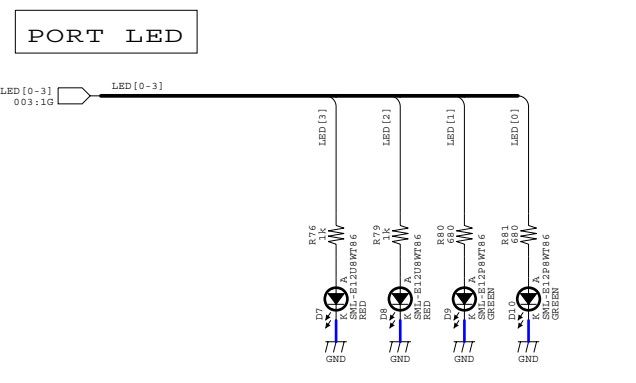
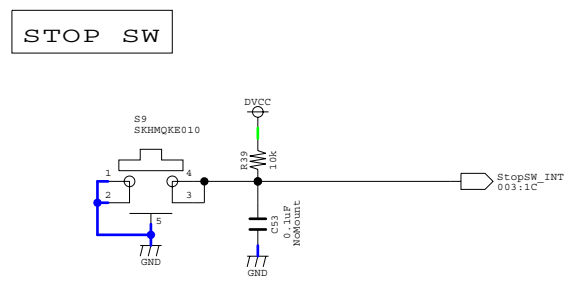
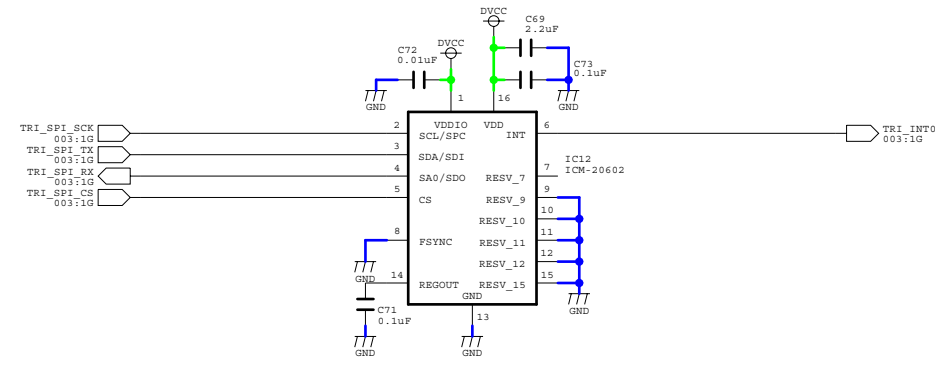

SPI Flash

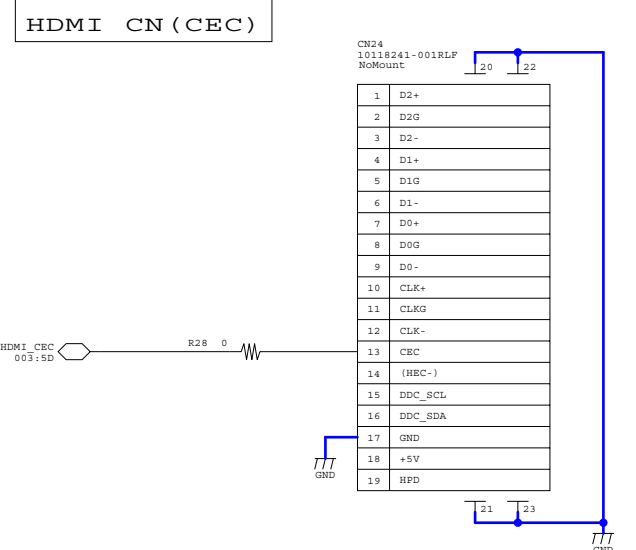
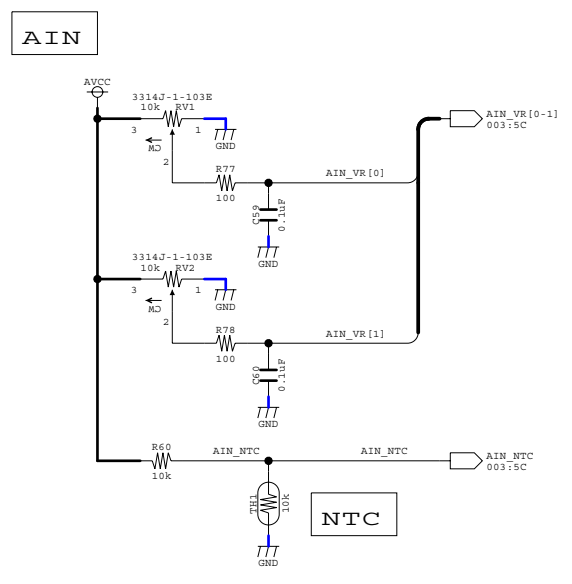
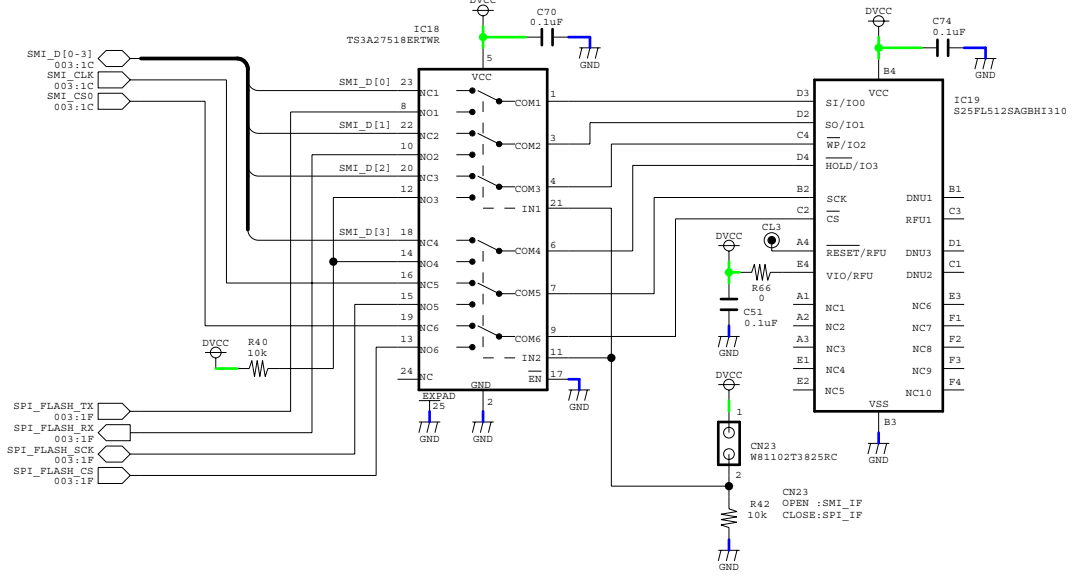

					Project
					Board Name
Rev	Date	作成	確認	承認	変更内容
	18/08/22 15:07:22 yamada				TMPM4G9_rev05.cir/00
					Page
					Page 5 of 5